

Advanced Structural Sandwiched Panels in Layered Corrugate Core

Dr. K Kamal, FIEI, FIIBE, FAIstructE, FACC(I)

C/o Department of Civil Engineering, Ajay Kumar Garg Engineering College,
27 Kmstone, NH-24, Adhyatmik Nagar, Ghaziabad 201009 UP India
drkkamal.jss@gmail.com

Nomenclature

- E, ν : Young's Modulus, Poisson's ratio
 q : Distributed load per unit area, positive load downwards
 a & h : Radius & Thickness of circular panel
 r, θ : Polar coordinates
 ρ : Non-dimensional radius r/a
 $f(z)$: Function defining sinusoidal corrugate of height ' h_c '
 Q : Non dimensional load qa^4/Eh^4
 ∇^2 : $(\nabla^2/\nabla r^2 + 1/r \cdot \nabla/\nabla r + 1/r^2 \cdot \nabla^2/\nabla \theta^2)$ & $\nabla^4 = \nabla^2 \cdot \nabla^2$
 W, \bar{w} : Displacement in downward direction, W/a
 Wr : Coefficient of Chebyshev series for W
 $Tr(\rho)$: The r th Chebyshev polynomial in the range $-1 \leq \rho \leq 1$
 $\bar{g}(\rho)$: Arbitrary function in the range $-1 \leq \rho \leq 1$
 G, V : Shear modulus, Shear Factor Ga^2/D_s
 N, M : Number of terms in Chebyshev series
 Superscript ' : First term of expansion to be halved
 Superscript ^(k) : Order of derivative.

Abstract -- Key highlights of design and development of the exclusive panel, having an additional shear layer in the mid of double corrugate orthogonally layered sandwiched core, that has been recommended for use as structural elements, are presented. Sandwiched panel with such a form of complex core, was first analysed using plate differential equation which was solved numerically, employing Chebyshev polynomials. Possibility of monolithic creation of such sandwiched panels for structural use has also been demonstrated as Hardware units, with utter ease were subsequently 3D-printed out successfully in thermoplastic materials on an FDM printer.

Keywords: Analysis, Chebyshev Polynomials, Double Corrugate Layer, Monolithic, Sandwiched core, Panels

I. INTRODUCTION

SANDWICHED panels are formed on assembly of two components namely (i) top and bottom Sheets/Laminates having at least each of a single layer and (ii) a thick core of different materials, to build the required cross sectional depths. These components are usually bonded together to utilize properties of each of these separate components into

an assembled sandwiched panel as an element offering the fullest structural advantages. Sandwiched structural panels by design therefore, have the deeper core, formed usually either of a honeycomb in metallic/aramid or created block of polymeric-Foam of required depths to provide separation to top and bottom sheets. These sheets with separation then, carry the entire tensions and compression developed due to any flexural loadings. An adequate bending stiffness is therefore inherently built into these structural panels. Core here, contributes as low as possible density to the overall structural sandwich panels and it remains responsible for taking full shear loads developed in the sandwiched panels under flexural loadings. This phenomenon may be visualised here in much identical manner as that observed in flanges and web of I-BEAM structural section, a proven and efficient structural element generally deployed in flexural load environments.

Sandwiched structural panels are extensively used in aerospace and transport sectors but the literature reveals use of sandwiched structural panels in other engineering sectors also [1, 2], but these have limited applications and may be found in places only when, much higher strength, higher stiffness, designed elements are needed and also when it remained not feasible to provide the same by flat or moderately thick sheets/laminates Fig-1a(i).

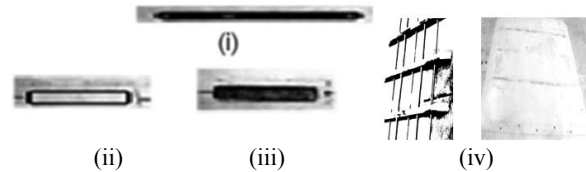
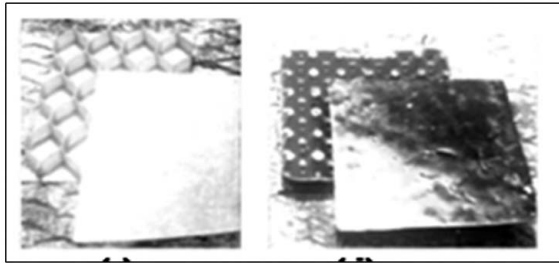

Figure 1a: Flat sheets to foamed core sandwich structural element construction.

Although, various types of cores have been in use, Honeycomb-core (as in Fig 1b), amongst most of other types of core used as sandwiched core in structural panels though the most expensive one, but it exhibits superior structural performance compared to other cores. Honeycomb-core sandwiched panels are thus widely adopted, mostly in aerospace applications.



(v) (vi)

Figure 1(b). Honeycomb-core (v) and Egg-tray type cores (vi) in structural sandwiched panels.

Owing to the real cost benefits, as also with required structural effectiveness, on the other hand, in other sector, applications of foam-core sandwiched panels can be traced in those commercial applications only that range from a small element to even some key structural elements, essentially and inherently required for high specific strength and specific stiffness. In civil Construction Industry application for instance, still it is a matter of concern, as for these sandwiched structural panels, firstly the flat sheets of construction materials or metal/laminates need be securely bonded on site, over top and bottom of the proposed core and, secondly, more importantly, sandwich panels construction applications invariably require deeper cores as compared to conventional cores. PU foams-cores for example, are in use for walls, floors, roofs, and foundations of any pre-fabricated buildings. Functionally, some sandwich panels are commercially also available as Structural Insulation Panels (SIPs) for similar use as cladding to the surfaces of any traditionally constructed buildings that only provide a barrier and help low down the transfer of heat through air.



(vii)

Figure 1(c). Stand-alone Corrugated Sheet, as structural element.

Stand-alone corrugated sheets as in Fig. 1c were also used as the structural panels some times, in early 19th century, specially in skins of the aircraft fuselage and wings. Analytical studies on use of these stand-alone corrugated sheets as structural elements were then reported also and are available in the literature. Considerable increase in the bending stiffness on comparison to that of a flat panel, on use of the corrugated sheet could be achieved, was already known. Similarly, corrugation oriented in axial direction were only effective whereas corrugations oriented laterally or circumferentially only lead to compensation of deformations and hence could only be deployed as crash cover sheets. Such corrugated sheets are being used in body buildings of boats as well as in girders

of Bridges fabrication with vertical corrugations of the webs. Skins on outer surface in aircraft, when used these corrugate sheets, this turned out only to the structural disadvantage from required aerodynamic behaviour [3]. Many theoretical expressions relevant for analysing these corrugated sheets as structural panels, were carried out by researchers the world over [4] and found that characteristics for example, of circular or sinusoidal corrugations, do not show up as the same in all directions. Structurally, this behaviour was correlated well similar to that of any orthotropic material panels and therefore in any further analysis of corrugate sheets these of substitute bending stiffness of equivalent orthotropic plate was suggested.



(viii)

Figure 1(d). Double-corrugate sheets with PU foam core in between as structural element.

Use of those panels, formed with a core out-of high density polystyrene foam, over which at top and bottom two separate corrugated sheets securely bonded, as depicted in Fig-1d were also reported in the literature and these are termed as double-corrugated sandwiched panels. These panels so developed and used may only be suitable in applications specially for architectural requirements as claddings, for example, for architectural roofs or on the walls, specifically when these walls are curved in shapes.

More recently, panels have also been engineered as sandwiched structural panels [5], on bonding top and bottom flat sheets/Laminates. over a single corrugated sheet/Laminates as a core. This type of sandwiched panels provide adequate strength/stiffness and also the required depths, These panels as structural elements so developed, generally suit for use in construction sector. One such structural panel type, was conceptualised on bonding two halves sets of section, each comprise of half thick corrugate layer together with either a full top or a full bottom sheets/laminates, when these sets were bonded/cured together then produced the sandwiched panels as shown in Fig. 1e and these are now used in some important field applications. Such panels are successfully used as trolley deck over two girders or as the continuous decking units in an GFRP foot bridge, designed and developed as also, reported earlier [6-7].

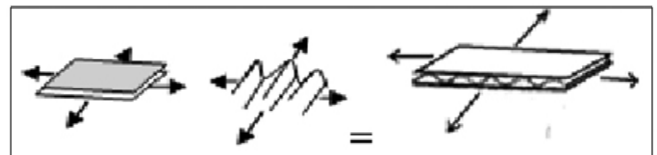

(ix)

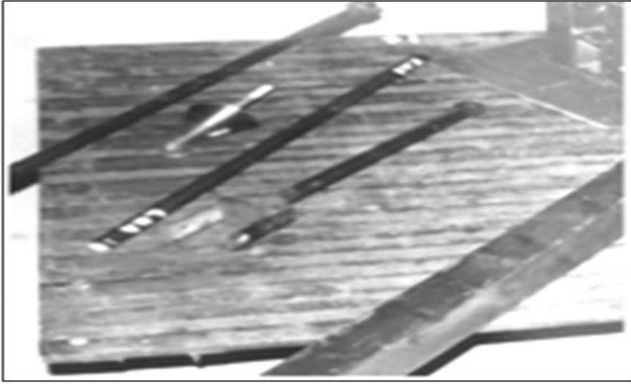

Figure 1(e). Corrugated GFRP laminate core sandwiched GFRP panels as deck units for foot bridges.

An addendum to the efforts in achieving more depths and also to exhibit further stronger, better structural and mechanical behaviours, a unique double corrugate layered core for sandwiched structural panels, possible to construct at site as well, has been developed now. Initially this was conceptualised by placing two units of such panels together as in Fig. 2a and simply bonding them one over the other. It was then observed as, in this arrangement, clearly, a mid flat layer is formed that subsequently need be created to eliminate the bonding process altogether. This layer thus acts as flat full length continued surface in mid between double corrugate layers and for effective use of a structural sandwich element this mid layer may also then be treated as a required shear layer within the core.

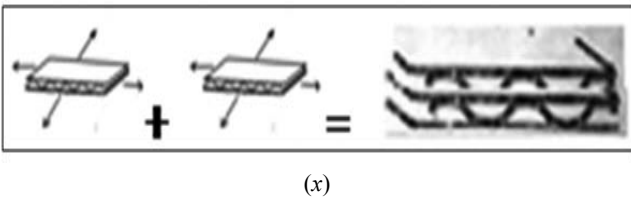

Figure 2a. Concept of double corrugate layered sandwich core in structural panels.

For the required sequential understanding of the structural behaviour of any such complex sandwiched core panels, analytical study is to be conducted first. In what follows therefore analytical study of a circular, sandwich structural panels so developed under an innovative in-house research project, is reported here, for example. The project undertaken was to address various distinct facets of the popular Fusion Additive Print Technologies that also may now be utilised in Construction Industry. Some efforts made under the project on creating ‘3DCMP’ printer was reported by the author earlier [8]. Hardware produced as a single corrugated core sandwiched structural panels, monolithically developed, prior to taking up further development of more complex double corrugate core with mid layers sandwiched panels, was the successful outcome of this project work so carried out.

II. ANALYTICAL STUDY

Ample information in the literature on various analytical and numerical techniques are available for solving governing equations to determine the deformations of plates. For predicting the behaviour of panels under any lateral, distributed loads ‘UDL’, an analytical technique for solving differential equation as well as integral equation in the form of Chebyshev Polynomials, for example, was needed as already used earlier employing Chebyshev series in range as $0 \leq \rho \leq 1$, and reported in the literature [9]. These Chebyshev Polynomials in range $-1 \leq \rho \leq 1$ were also adopted by the author [10] further, to solve the governing differential equation of circular plates and studied for their Dynamic response.

For the purpose of understanding structural behaviour from those analytically obtain deflections and slopes at various points in any circular sandwich panel subjected to static UDL for example, has been carried out here and is as reported below. Here the corrugation has been developed out of isotropic base sheet material that, tend its characteristics to any orthotropic layer behaviour, thus two corrugate layers here as taken stacked orthogonally one over the other, can conveniently be analysed and predicted for the lateral displacements at various points on the panel, caused due to stress resultants imposed all along the sandwich cross section, the sandwiched cross section. Therefore here an equivalent flat plate/laminate with five layers thick with substitute stiffness value D_s of the panels has been derived first. This panel’s differential equation now also includes effect of a layer as created within the core appropriately. D_s value was plugged into the differential equation and solve for such circular panels respectively with simply supported and Clamped all round edges. Numerical calculations from solution of such panel equations are carried out here as well, employing the Chebyshev polynomials since it was reported earlier [9, 10] as a rapidly converging and one of the best analytical techniques. Several numerical results on a laptop computer were obtained and plotted in the form of design charts. Many fruitful observations were then made here from the pattern of deformation so plotted for circular, sandwiched panels. Structural advantages from these charts therefore studied in detail and then based on such study, use of these sandwich panels as structural elements has been recommended for Civil Engineering applications.

Mathematical Formulation: Structural sandwiched panel considered here is with its profile comprises of three flat layers - at top, middle, bottom and orthogonally stacked double corrugated layers as depicted in Fig. 2(a) and (b). Owing to maintain a symmetry in cross section, a uniform thickness ‘t’ of each of these layers when used, the depth of sandwich panel becomes ‘ $4hc + 3t$ ’ and the thickness of its equivalent panel then considered here as

$$h = t\{3+2(S/L)\} \tag{1a}$$

As the sinusoidal geometry of corrugation has been considered here with each corrugation of height ‘ h_c ’, from own axis and its single wave form length ‘ $2L$ ’, then any such corrugate layer is defined as

$$f(z) = h_c \sin(\pi/L)y \tag{1b}$$

Further, the same corrugation in terms of an angle ‘ ϕ ’ made by a tangent to the layer at a distance y at own axis, is also given as

$$f(z) = \sqrt{[h_c^2 \cdot (\pi/L)^2 - \tan^2 \phi]} / (\pi/L) \tag{1c}$$

For analysis of this corrugated sandwich section with 5 layers, the equivalent materials sheet flexural stiffness ‘ D_s ’ is computed first for the section as in Fig. 2(b), and that differs from ‘ D ’ in case of flat plate as calculated here as below

$$D_s = \frac{E(1-\nu^2)}{(1-3\nu^2-2\nu^3)} \cdot \left[\sum_{k=1}^5 \left\{ \int_{z_{k-1}}^{z_k} Z^2 dZ \right\} \text{for } k=1,3,5 \right. \\ \left. + \left\{ \int_{z_{k-1}}^{z_k} \int_0^{2L} Z^2 \cdot h_c^2 \cdot \sin^2(\pi/L)y \cdot \sqrt{[1+(\pi/L)^2 h_c^2 \cos^2(\pi/L)y]} dy dz \right\} \right. \\ \left. + \int_{z_{k-1}}^{z_k} Z^2 / [1+(\pi/2L)^2 \cdot h_c^2] dz \right] \text{for } k=2,4 \tag{2}$$

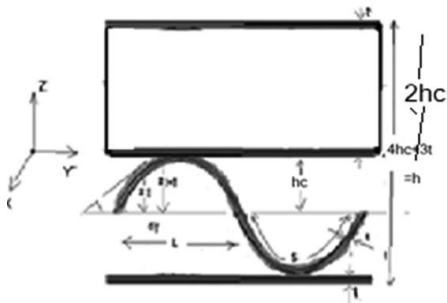

Figure 2b. Double corrugation with shear layer.

Governing differential equation in polar coordinates of circular panel with its diameter ‘ $2a$ ’, total depth of sandwich core alone of ‘ $4h_c+t$ ’, for example, with its edge either simply supported or clamped all round, and subjected to static UDL of intensity ‘ q ’ is then expressed as [11]

$$\nabla^4 W + G/D_s \cdot \nabla^2 W = q/D_s \tag{3a}$$

Or

$$\{(\nabla^2 / \nabla r^2 + 1/r \cdot \nabla / \nabla r + 1/r^2 \cdot \nabla^2 / \nabla \theta^2) + G/D_s\} \cdot (\nabla^2 W / \nabla r^2 + 1/r \cdot \nabla W / \nabla r + 1/r^2 \cdot \nabla^2 W / \nabla \theta^2) = q/D_s \tag{3b}$$

This governing differential equation as in Eq.(3) above has been solved by adopting Chebyshev Polynomials and the solution to the problem is assumed here as

$$\bar{w} = \sum_{r=0}^N \bar{w}_r T_r(\rho) \tag{4a}$$

Any given function is expressed as a sum of the Chebyshev polynomials as

$$\delta(\rho) = a_{0/2} \cdot T_0(\rho) + \sum_{r=1}^N a_r T_r(\rho) \tag{4b}$$

wherein, r^{th} polynomial in a Chebyshev series is defined as

$$T_r(\rho) = \cos r \theta, \quad \cos \theta = \rho; \quad -1 \leq \rho \leq 1 \tag{4c}$$

Chebyshev polynomials obey their properties of orthogonal functions as

$$\int_{-1}^1 (1-\rho^2)^{1/2} T_m(\rho) \cdot T_n(\rho) d\rho = \begin{cases} 0, & m \neq n \\ \pi/2, & m = n \neq 0 \\ \pi, & m = n = 0 \end{cases} \tag{4d}$$

On substitution of (4a) in differential equation Eq (3) above the same becomes as

$$\sum_{r=0}^{N-4} \left[\left\{ \bar{w}_r^{(4)} + 3/2 (\bar{w}_{r-1}^{(4)} + \bar{w}_{r+1}^{(4)}) + 3/4 (\bar{w}_{r-2}^{(4)} + 2 \cdot \bar{w}_r^{(4)} + \bar{w}_{r+2}^{(4)}) + 1/8 (\bar{w}_{r-3}^{(4)} + 3 \cdot \bar{w}_{r-1}^{(4)} + 3 \cdot \bar{w}_{r+1}^{(4)} + \bar{w}_{r+3}^{(4)}) + 2 (\bar{w}_{r-1}^{(3)} + \bar{w}_r^{(3)} + \bar{w}_{r+1}^{(3)}) + 1/2 (\bar{w}_{r-2}^{(3)} + 2 \cdot \bar{w}_r^{(3)} + \bar{w}_{r+2}^{(3)}) \right\} \right. \\ \left. - \left\{ \bar{w}_r^{(2)} + 1/2 (\bar{w}_{r-1}^{(2)} + \bar{w}_{r+1}^{(2)}) \right\} + \bar{w}_r^{(1)} + 1/4 \left\{ \bar{w}_r^{(2)} + 3/2 (\bar{w}_{r-1}^{(2)} + \bar{w}_{r+1}^{(2)}) + 3/4 (\bar{w}_{r-2}^{(2)} + 2 \cdot \bar{w}_r^{(2)} + \bar{w}_{r+2}^{(2)}) + 1/8 (\bar{w}_{r-3}^{(2)} + 3 \cdot \bar{w}_{r-1}^{(2)} + 3 \cdot \bar{w}_{r+1}^{(2)} + \bar{w}_{r+3}^{(2)}) + \bar{w}_r^{(1)} + 1/4 (\bar{w}_{r-2}^{(1)} + 2 \cdot \bar{w}_r^{(1)} + \bar{w}_{r+2}^{(1)}) + (\bar{w}_{r-1}^{(1)} + \bar{w}_{r+1}^{(1)}) \right\} \right] \cdot T_r(\rho) \\ = a^3 / 16 D_s \left[\sum_{r=0}^N \left\{ q_r + 3/2 \cdot (q_{r-1} + q_{r+1}) + 3/4 \cdot (q_{r-2} + 2 q_r + q_{r+2}) + 1/8 (q_{r-3} + 3 q_{r-1} + 3 q_{r+1} + q_{r+3}) \right\} \right] \cdot T_r(\rho) \tag{5}$$

Solution of this differential equation comprise of the unknowns which are function of one or several variables and contain not only the function themselves but also their derivatives which are obtained numerically imposing the edge condition considered here as simple support and clamped at the edge which are defined respectively as

at $\rho = +1$, for simply supported edge

$$\sum_{r=0}^N \bar{w}_r T_r(\rho) = 0 \tag{6a}$$

$$-D_s \left[\sum_{r=0}^{N-3} \left\{ \bar{w}_r^{(2)} + 1/2 (\bar{w}_{r-1}^{(2)} + \bar{w}_{r+1}^{(2)}) \right\} + \bar{w}_r^{(1)} \right] = 0 \tag{6b}$$

or for clamped edge

$$\sum_{r=0}^N \bar{w}_r T_r(\rho) = 0 \tag{6c}$$

$$\sum_{r=0}^{N-1} \bar{w}_r^{(1)} T_r(\rho) = 0 \quad (6d)$$

and a condition that need also be satisfied for circular panels at the centre $\rho = -1$

$$\sum_{r=0}^{N-1} \bar{w}_r^{(1)} T_r(\rho) = 0 \quad (6e)$$

$$\sum_{r=0}^{N-3} \bar{w}_r^{(3)} T_r(\rho) = 0 \quad (6f)$$

Numerical Calculations

Different numerical values were assigned to the design parameters including geometry ‘ ρ ’, shear layer effect ‘ V ’, the non-dimensional load ‘ Q ’ and the normalised deformation ‘ \bar{w}/h ’ all along the diameter $2a$ of the circular, sandwiched panels under such assigned values respectively were then obtained. A variation starting with -1 for ρ and zero for both Q & V respectively were increased then to certain required maximum, for example here as +1, 20 and 5 respectively. The downward deformations from neutral axis, at various points, have been obtained for panels with edge conditions as simply supported and clamped all round respectively. These parametric values were varied in steps appropriately and the resulting normalised deflection \bar{w}/h of sandwiched panel at various points were obtained and plotted in the form of generalised design charts.

III. RESULTS AND DISCUSSIONS

From the numerical results obtained out of this analytical study, certain behaviour and also effectiveness on their use as sandwiched panels with required inbuilt structural benefits have been ascertained. From these behavioural pattern arrived from plots of normalised deflections \bar{w}/h values at various points along diameter of the circular panels is for any static, UDL. This pattern for any circular panels with SS or clamped edge, show different variations in downward deflections value. This pattern itself here, acts as a generalised, design chart for any other circular panels. One can, for example, obtain the desired results at any point for a circular panel just by multiplying the calculated value of ‘ Q ’ of that panel load, to the read values of normalised deflection at that point from this design chart. Numerical values of \bar{w}/h at the centre also when plotted with varying values of a few calculated Q , for example, show a clear reduction in \bar{w}/h . due to the presence of shear layer as also on further varying values of parameter V , representing the mid layer, thickness effect thus are also obtained here. Central deflections pattern as in Fig. 4 (a) and Fig. 4(b) show considerable drop for example, in values of \bar{w}/h in both edge conditions as SS and clamped respectively. Further, sandwich core in the panels once provided with a shear layer in the mid (use D_s), small gain/advantage on layer thickness effect has been found variation in V values on representing such shear layers. Another design chart as plotted for values of \bar{w}/h , except for $V = 0$, for example is shown in Fig. 5a. This reflects

a reduction in values of \bar{w}/h at several points along the diameter from one support edge to the mid of the panel for any variation in the non zero values of V . This chart also explains that a clamped edge sandwiched circular panel be preferred over the same with SS edge in structural applications. Further as it should be, when plotted the values of normalised deflection \bar{w}/h wrt that of a clamped panels (but use of ‘ D ’) without any sandwich core, the \bar{w}/h values of panels with and without sandwich layers for example, while as considerably reduced, in case of panel edge with SS, Fig. 5(b), is observed whereas, the same tend to vary little for those panels with clamped edges under identical load conditions.

All these generalised charts are furnished here for ready use in design of any circular structural panels with (use ‘ D_s ’) or without any sandwich core (use ‘ D ’).

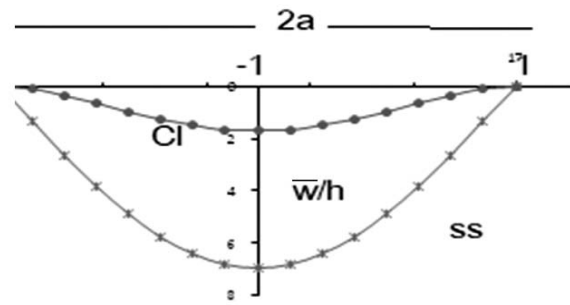

Figure 3. Downward deflections (\bar{w}/h) at various points along dia of panels under UDL of unit value Q

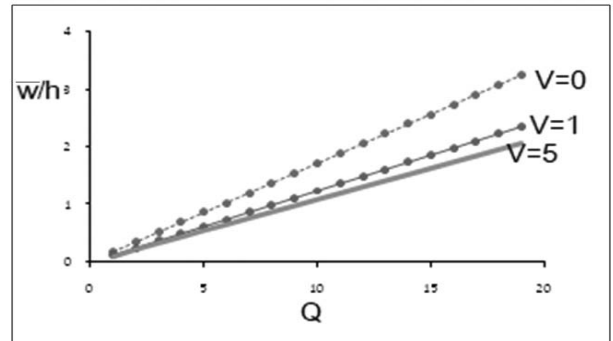

Figure 4(a). Presence of shear layer influence the flexural behaviour under various Q values, for circular panels of clamped edge.

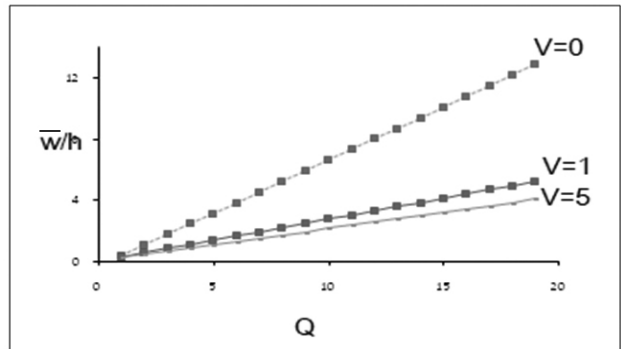

Figure 4(b). Presence of shear layer influence the flexural behaviour under various Q values, for circular panels of SS edge.

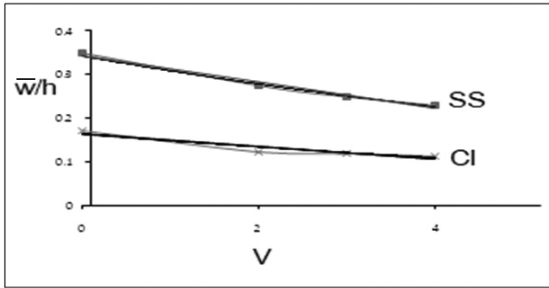

Figure 5(a). Influence of non-zero V on central deflections for SS and clamped panels.

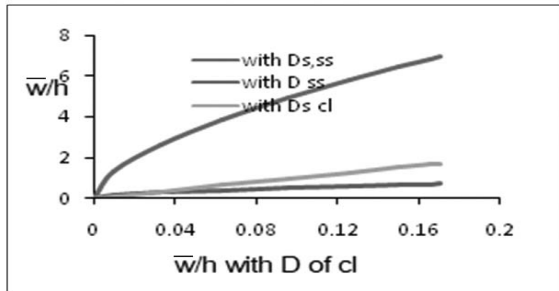

Figure 5b. Influence of non zero V values on the \bar{w}/h , of ss & Clamped panels all wrt to that of clamped panels with $V=0$.

IV. MONOLITHIC PANEL HARDWARE

Designers and Architects in the construction industry, so far remained bound only to choose in their projects some identical and simple geometry, employ simple sections of structural elements. Construction of any sandwich panels in itself, remained almost absent as these were requiring some suitable bonding materials and/or their formations called for, a labor intensive process on site.

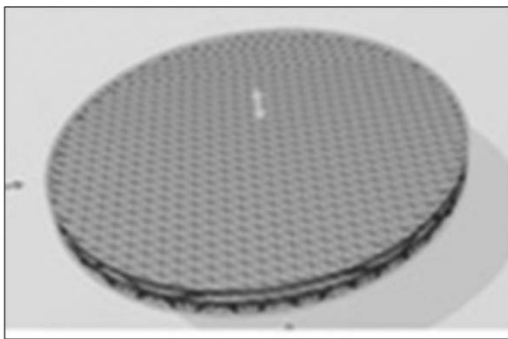

Figure 6. A 3D-CAD soft model converted into STL file subsequently used in FDM printer.

There has been a felt need for a newer, better and easy to handle production process at sites, for structural elements to be use in construction. With a growing interest of construction industry adopting AM technique such as used in 3D printing, it is felt that, this technique can especially deal with, creating any geometry now. Therefore deployments of any such

complex corrugates sandwiched core between two flat layers, once monolithically created as sandwich panels, will surely find applications as structural element. These panels have increased higher load carrying capacities and other structural advantages. Possibility to create monolithically such Hardware of structural sandwich panels in profile that consist of a mid flat layer between a double corrugations core as has been realized here, was proved soon after the rectangular panels with single corrugate layer were monolithically produced in one piece and successfully demonstrated [12]. A circular panel for example, with this double-corrugate layered sandwiched panel has been made now and demonstrated here after it has been 3D-printed out. For this demo however, a solid 3D-CAD model was used and same was then converted into STL file (Fig. 6) on a PC attached to a 3D printer (Fig.7a). Hardware, in thermoplastic has been monolithically 3D-printed out using FDM based printer successfully with utter ease. In Fig. 7(c) and Fig. 7(d), this Hardware of complex sandwich core section as conceptualized is shown in two orthogonal views respectively. From this demonstration of printing successfully the exclusive corrugated sandwich profile, it is believed that any such circular/rectangular sandwich panels can be created and used, will then provide all required structural benefits which will also prove effective in civil construction Industry.

Further, it is felt that possibility also exists to develop any such sandwiched panels in construction mix in near future with utter ease. Attempt was already made in this direction as on the lines of a commercial grade 3D-printers, scaling on in-house 3DCMP[8], printer was then developed for use at CE Department that deals with use of concrete mixes.



(a) FDM based commercial grade developed printer used



(b) single corrugate Sandwich monolithic panel hardware

Figure 7 (a) Single corrugate sandwiched core monolithic rectangular panel as 3D printout.

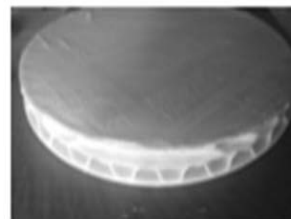

View 1

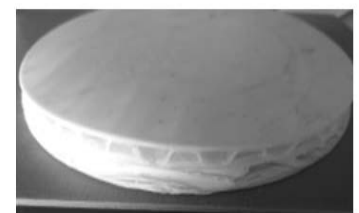

View-II

Figure 7(c) Hardware as conceptualised with core, one side and another orthogonal side views

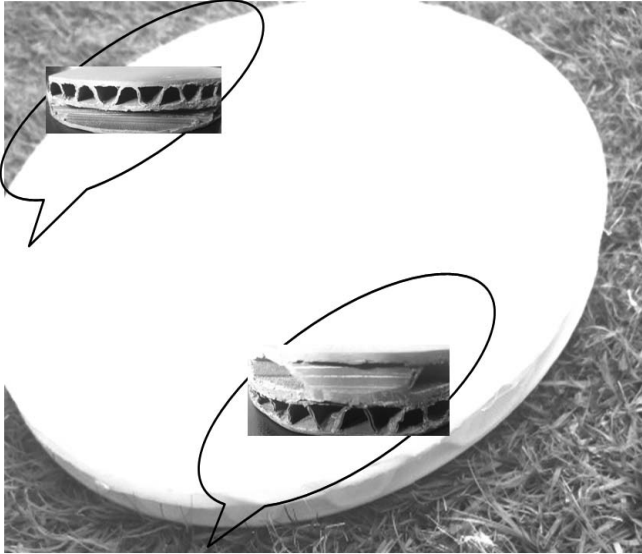

Figure 7(d). Conceptualised double corrugated sandwich core monolithic sandwich circular panel hardware.

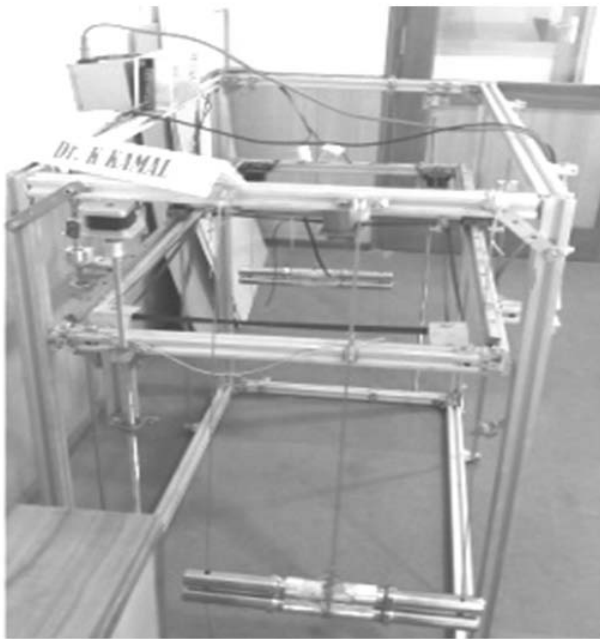

Figure 8. An in-house scaled up '3DCMP', printer for dispensing the construction mix materials.

V. CONCLUSION

Graphical representation of numerical values obtained from this analysis resulted in design charts are for applied unit load, *i.e.* $Q=1$, and hence for computed values of Q , for any circular panels, the normalised deflections \bar{w}/h of the panels can be arrived at all along the diameter of any circular panels using computed Q as multiplier to the respective values of \bar{w}/h read on this chart. From this study, it has been clearly understood that adopting the proposed exclusive sandwich corrugated core

profile, since can now be developed with ease, will offer, further enhanced load carrying capacities, increase stiffness, reduce construction costs and keep weights to bare minimum, of structural element for varieties of civil engineering applications. Monolithically developed such panels through 3D-printers, as demonstrated here successfully, also opens possibilities to construct such corrugated sandwich panels in concrete mix with ease and also to use. To achieve this, a type of printer as '3DCMP' in-house developed for example, holds the future promise on several construction aspects including many complex geometries as well as such more complex sandwich profiles for structural panels.

ACKNOWLEDGEMENT

Author remains thankful to Dr R.K. Agrawal, D.G., AKGEC for his constant encouragements to carry out innovative research activities at Departments of AKGEC. A National Seminar was organised with Financial Support extended by SERB, DST, GoI, wherein an FDM based 3D printer, then developed by Sri Pradeep Jain, was demonstrated successfully to all the participants.

REFERENCES

- [1] K. Kamal, D.K. Murthy and S.R. Dharwadkar, 'Modernization of bridge decking panels through GFRP', *Proc. All India seminar on composite materials and application*, Ahmedabad, 4-5th September 1992
- [2] K.Kamal, V.B. Khire, S.S. Kulkarni, S.R. Dharwadkar and M.R. Joshi, "Development of PUF Sandwich Filler panels for a Mobile Bridge", *Proc. Aerospace Composites, Challenges and opportunities*, COMPOSITES'94, pp-375-396, 17-18 February Trivandrum, 1994.
- [3] S. Barbarino, O. Bilgen, R.M. Ajaj, M.I. Friswell and D.J. Inman, 'A Review of Morphing Aircraft'. *Journal of Intelligent Material Systems and Structures*, vol. 22, no.9, pp.823–877, 2011.
- [4] M.C. Winkler, 'Analysis of Corrugated Laminates', Diss ETH no. 20130, Zurich, 2012.
- [5] K. Kamal, S.R. Dharwadkar and M.R. Joshi, "Development of Decking units in FRP to improve the performance of a bridging system", *Proc. ISAMPE, Conference & Exhibition on Fibre Reinforced Plastics, Composites and their Applications*, CEFCA-93, Bangalore, pp.V-12 – V-24, August 1993.
- [6] K. Kamal and M.R. Joshi, "On the use of advanced composite corrugated core sandwich laminates as structural panels", *Proc. ISAMPE National Conference on Composites-INCCOM 10*, RDE(E), Pune, November 18-19, 2011.
- [7] A.K.V. Pandalai, "Rectangular GFRP Structural Panels", Articles published in CPDM, Vol.II funded by DST,GoI, TIFAC (1993-95).
- [8] K. Kamal and P. Tiwari, '3D construction mix printer (3DCMP) fitted with a disposable, dispenser cum extruder unit' Construction Management tools in built environment', *Journal of IBC*, vol. 27, no. 1, pp. 43-47, 2019,
- [9] S. Alwar and Yogendra Nath, 'Application of Chebyshev polynomials to the Nonlinear Analysis of circular plates' *Int Journal of Mech. Sci.*, vol 8, pp. 589-595, 1976.

- [10] K. Kamal, 'Dynamic response of circular plates on elastic foundation' ME *Disquisition* submitted to Department of Civil Engineering, MNREC, Allahabad, 1978.
- [11] S, Timoshenko and S.K. Woinowsky, *Theory of Plates and Shells* McGraw-Hill Book Co. Inc NY, pp-39, 260-265 and 558-56, 1978.
- [12] K. Kamal, Kshma Shukla and Prasant Agarwal "Development of corrugated sandwich profile panels in designed mix from a 3D construction mix printer, *Proc. 1st International Conference on 3D Construction Printing*, Swinburne University of Technology, Melbourne Australia Paper 034, 25-28 November 2018.



Dr K. Kamal obtained Doctorate degree in Structural Engineering from Indian Institute of Science (IISc), Bangalore, India. In 1984 he taught undergraduate as well as postgraduate students of construction technology in Civil Engineering Department at BMS College of Engineering, Bangalore.

Worked on prestigious LCA/Tejas project of MoD, Govt. of India and subsequently, as Head Composite Research Centre for DRDO at R&DE(E), Pune where he executed several Advanced Composite Products Design & Development projects for Civil Engineering as well as a few for IGMDP applications. He was then Director (TUD) and became Adviser, DSIR, MoST, GoI.

Subsequent to his superannuation from GoI, he re-joined to serve academics as Professor of Civil engineering. He worked respectively at JSSATE Noida and AKGEC under AKTU and JSSATE Bangalore under VTU. During this period, he was Principal, JSSATE, Noida for two years and thereafter Dean (R&D) & HoD (civil), at AKGEC, Ghaziabad for one year.