

Photovoltaic Applications in Development of Solar India

Chandani Sharma¹ and Dr. Anamika Jain²

Department of Electronics and Communication Engineering, Graphic Era University, Dehradun 248002, Uttarakhand, India

¹chandani19nov@gmail.com, ²anamikajain2829@gmail.com

Abstract-- Solar Power generation in India ranks within top five countries of world in Green energy revolution. Photovoltaic (PV) cells, or solar cells, are active photoelectric system converting sunlight to electricity. India's economic growth has been hindered by shortage of electricity since transmission and distribution losses have been extremely high over the years due to urban theft. Thus, use of solar needs to be commercialized for economic development in India. Towards planetary mission, solar use is being promoted in applications like street-home lighting systems, solar lanterns, PV power plants, water heaters, solar cookers, agro-photovoltaic pumps, large solar arrays, and solar powered portable lighting devices, rooftop panels; pedal powered classrooms, green parks, green cities, standalone and grid structures etc. The capital investment in establishment of solar unit is not too large since costs of land & building is not included. The machineries of the units are fabricated by suppliers or local engineering workshops. The plants can be installed in villages of small scale industry production catchment. Considerable research work has been done at ICAR Institutions together with NISE, SEC, MHRD and NGOs in this direction. However, visible impacts are not seen on the real ground perhaps due to low risk capacity, limited internal resources and poor access to solar resources in areas of these entrepreneurs. In this paper the present status and future needs for technovations and management skill in the areas of solar power extraction efficiency and value added techniques with applications and overall modernization of solar PV processing, storage and marketing, etc are mapped and discussed.

Keywords: Photovoltaics, Green energy revolution, Solar power extraction efficiency, Value added techniques with applications.

I. INTRODUCTION

ENERGY is the foundation stone of human development. With all these developments, sufficient solar technologies have to be envisaged for getting maximum utilization of available renewable energy technologies. Solar Energy is abundant, decarbonised and distributable but in spite of its vast potential it is still a miniscule. As concerns India's investment sector, recent year's growth shows that solar use has consistently increased by 20-25%. Solar implementation finds applications in areas by (1) Solar Thermal (ST), (2) Solar Photovoltaic's (SPV) and (3) Solar Hydro (SH). Solar Thermal uses solar collectors for capturing solar power and use for cooking and heating purposes.

Solar PV uses solar cell panels that absorb sunlight and emit photons for electricity generation. Solar Hydro is operated over perennial streams or water reservoir for cooking, heating and electricity generation. Since PV appears to be more flexible, economic and simpler it is used mostly on commercial scale for electric applications.

Basically solar photovoltaic panel comprises solar cells that convert visible solar energy into electricity using photoelectric effect. The effect causes photons from sunlight to be absorbed on surface of mono crystalline or polycrystalline solar cell panel. This draws out valance electrons to jump into conduction band. As a result, large number of free electrons are available for current flow in circuit. This current when controlled by proper alignment of solar cell modules can be used for various applications and transformed for transmission and distribution of supply as per utility. PV can be mounted on supporting structures for individual standalone structures or mass suitable Grid structures. Standalone are mini wattage devices designed to operate independent of electric supply for household DC/AC loads without any storage. Grid structures incorporate parallel interconnected utility electric supply in ON grid or OFF grid conditions with battery backup. Since PV either standalone or grid systems require less maintenance, environment issues and emission concerns they appear to be more sustainable in power potential proposals. Further electric constraints like design dimensions, operating voltage, power and current limits, temperature switching and lifetime factors make solar appliances perfect for usage.

Application areas of PV have a vast scenario. Case studies reveal from south to north or east to west everywhere solar potential is being harnessed for profitable energy ventures in India. Latest endeavors are being tested towards achieving demand of 1.748 lakh MW energy from solar wherein generated supply is just 1.3 MW power. Various incentives are centralized for achieving higher growth rates as indicated by JNNSM (Jawaharlal Nehru National Solar Mission) and MNRE (Ministry of Power and Ministry of New and Renewable Energy).

A review of PV ventures installed in India with their availability is given in Table 1.

TABLE 1: PV SYSTEMS STATISTICS

S.N.	Application Area	Available systems	Installations (millions)
1	Electricity Generation (EG)	Rooftop Grid	1.2
2	Powered Electronic Appliances (PEA)	Lighting Charging Appliances	3.2
3	Solar Water Pumps (SWP)	Solo Monedo	7,771
4	Solar Industries (SI)	Small Scale Telecom	110 MW (OFF Grid) 17.82 (ON Grid)

It is clear that powered electronic appliances have boosted solar performance sharply inducting new technologies. In succeeding section, various approaches and techniques for PV applications with available systems listed above are discussed. Novel devices with features employing automatic expert systems using faster computation techniques are also highlighted.

II. APPLICATION AREAS OF SOLAR ENERGY

Relative to electricity generation, processing and distribution purposes rural areas use kerosene, diesel or propane to power generators for processes of household, agriculture or industrial operations. Although they contribute to power generation, certain drawbacks like transportation over location, production of noise and fumes emission with proper care desired in handling are also present. Generators require a significant amount of maintenance caused due to break down or wear and tear of accessories. Moreover, solar appliances are simple in design with low maintenance costs and easy trouble shooting. Being light comparatively they appear to be best for use in enhancing remote areas connectivity. Relative to basic needs of food, clothing and shelter, photovoltaic products are synthesized upon. Powered water pumping systems extend to meet a broad range of water needs. PV pedaled structures provide a good back-up to achieve low power mission. As illustrated in Table 1, new tools of PV in remote electrification are discussed below:

ELECTRICITY GENERATION (EG)

Solar PV can trap sunlight to generate electricity from few Kilowatts *i.e.* a micro grid extended to hundreds of Megawatts in mega power plant. It is subdivided into Rooftop or Grid distribution.

Rooftop Generation Fig 1(a) can generate electricity as per requirements within a solar home through solar panels mounting at sides of home or rooftop distributed panels. Generally these systems act as micro power plant to serve basic electric needs

of building. However, to improve performance for operating over long span of time and tolerant to no sun conditions they can be connected to Grid.



Figure 1 (a). Rooftop Building Management System (BMS).

To operate electricity distribution using solar for cluster of houses as in solar village or city, Grid structures are used. Here, number of panels determines outputs of Grid installed over spacious locations for generation of electricity as in Figure 1 (b).

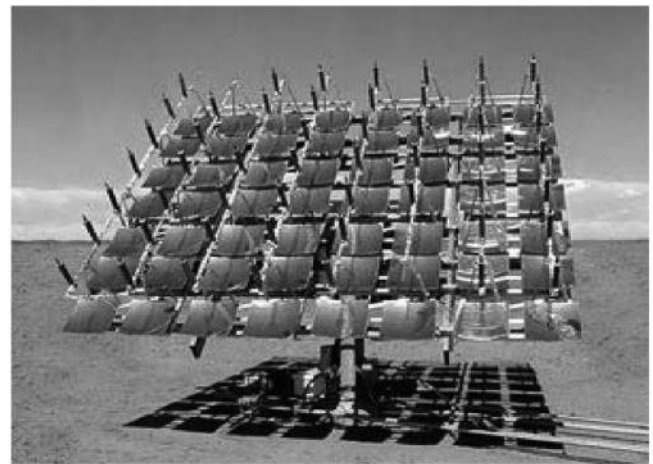

Figure 1(b). Concentrated Solar PV Plant .

POWERED ELECTRIC APPLIANCES (PEA)

PEA relates to equipments running by PV that can be worked for running electric appliances. The most commonly used solar lanterns, street lights, CFL's and power kits give an impulse too solar lighting. These are depicted by Fig. 2(a).



Figure 2a. Solar Lantern and street lights.

Modern Lighting in buildings mainly focus on Sox Lamps and Solar powered projectors. The main advantage of these is that their operating temperature fixate that can be provided by controls with no filaments to burn out. Fig. 2(b) represents sox lamps alternatives to old street lights.

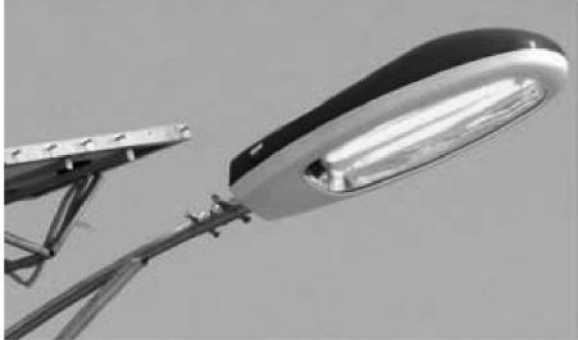

Figure 2b. Sox lamps.

Batteries (DC or AC) associated with solar panels are charged during daytime. Bags and Umbrella industries are focusing on developing products that can use to charge mobiles. Sometimes battery bank may overcharge and limit current. Thus Solar Charge regulators or controllers are available similar to Fig. 2(c).



Figure 2c. Solar Charge Control llers.

By endeavors of R & D solar appliances are innovated for solution to energy demand-supply crisis. One such solar plug in appliance includes mini coolers as in Fig. 2(d) for evaporation purposes within building. Based on similar construction exhausts can also be planted within rooms.

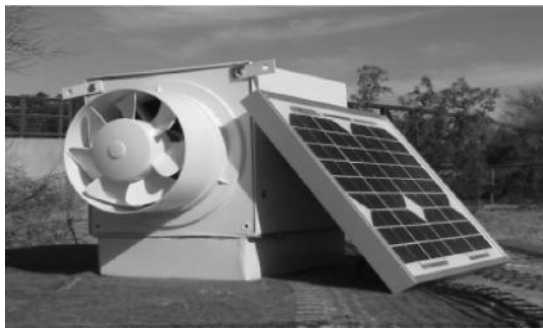

Figure 2d. Solar powered Mini Cooler.

Solar AC's and Solar Refrigeration is an adapting solution for climatic changes caused due to CFCs (Chlorofluorocarbons). They are boon to serve perishable products and medicines. Fig. 2(e) shows Solar Refrigerator.

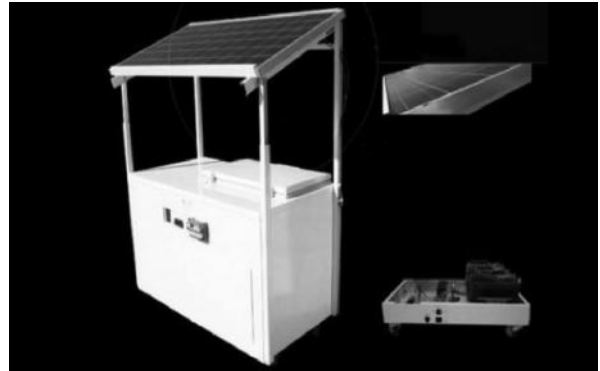

Figure 2e. Solar Refrigerator.

Catering and household applications of solar comprise box type solo or community cookers that may be constructed using single or double reflector units. In order to incorporate multitasking, baking units and solar canteens are being focused upon.

Cooking vessels using parabolic arrays provide a source of large absorption of sun rays. Tirupati Green Temple uses parabolic dish type solar cooker as in Fig 2(f) for fooding of thousands of devotees.



Figure 2f. Parabolic Solar Cooker.

SOLAR WATER PUMPS (SWP)

The unpredictability of direct water supply in rural areas creates uncertainty always as concerns operated motors for and generator sets for watering fields. Solar water pumps can be connected for water drinking or other purposes like space heating, cooling and drying, water desalination etc. Solar water pumps and sprayers for a single user in domestic purposes

can be used to lift up water from underground. They can bore upto 100 meters and draw water out of grounds as in fountains or water boring systems in field. Fig. 3(a) shows solar panel connected to motor set for drawing fresh water followed by 3(b) that shows SSWS for a small field or borders lining field.



Figure 3a. Solar water tank using motor



Figure 3b. Small field beds irrigation using SSWS

SOLAR INDUSTRIES (SI)

Solar basin still can be a good source for obtaining distilled purified water. Figure 4a shows its construction using simple blackened box for storage and heating water. It uses a glazed top. Water is purified by evaporation and temperature which leaves behind contaminants purifying water.



Figure 4a. Solar Basin Still.

Solar cocoon stifler is used in sericulture for silk preparation. It uses electric oven to kill pupa. If pupa is not killed it can damage silk fibers. Thus it uses electric motor driven by solar for silk generating as represented in Figure 4b.



Figure 4b. Solar Cocoon Stifler.

Green Schools and clean classrooms are being prepared on solar generated pedaled devices. They can be boosted for real time purposes along with power generation. Fixed solar powered bikes displayed in Figure 4c can be a substitute to heavy gym machines in hostels or publically.



Figure 4c. Pedal power bike.

Solar farm equipments like tractors, ploughers, aerial jets, pest control sprays and other driving vehicles are increasingly being preferred by farmers. Fig. 4(d) and (e) show some agro-industry machines.



Figure 4d. Solar powered tractor.



Figure 4e. Farm equipment.

In telecom solar finds topmost place amongst any other RET's (Renewable Energy Technology). Fig. 4(f) shows solar telecom tower technology. The section used to drive Base transceiver station (BTS) consists of solar panel whose output is given to DC box comprising CCU, MPPT (Maximum Power Point Tracker) connected via SMPS (Switched Mode Power Supply) to battery bank.

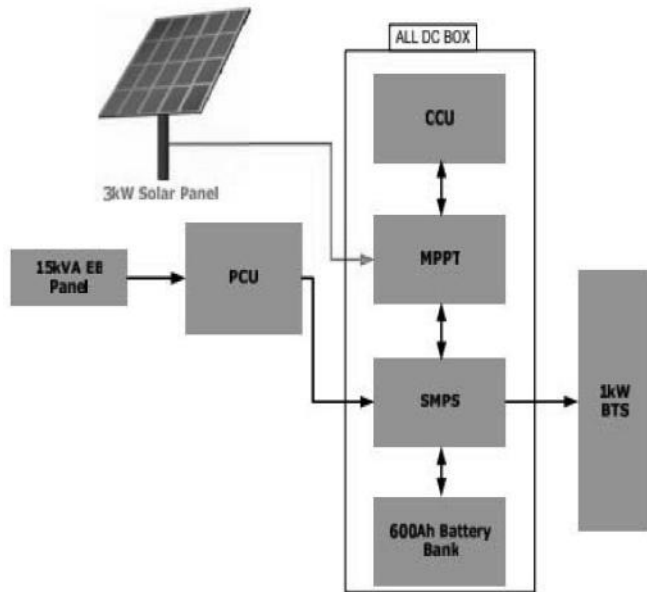

Figure 4(f). Solar telecom/mobile tower technology.

III. CONCLUSION

Solar market in India has been offering a host of business opportunities in the form of new target markets, possibilities to exploit technological advantage using PV. India receives 5000 trillion KWhr that is about 20MW per square km per

annum solar energy that provides ample opportunities to be developed as green country. The practical implementation of solar applications can be boosted even for varying temperature and irradiance. However, the challenges in this sector towards globalization are to be met by proper tracking using appropriate measures for preparing Solar India.

IV. REFERENCES

- [1]. "Access to Clean Energy "A glimpse of off grid projects in India" ,Government of India Ministry of New & Renewable Energy Report.
- [2]. "Jawaharlal Nehru National Solar Mission Phase II" Government of India Ministry of New & Renewable Energy Report.
- [3]. B.C. Ramachandraa, Rishabh Jain, Gautham and A Krishnadas, "Hotspots of solar potential in India", *Renewable and Sustainable Energy Reviews*, Volume 15, (2011) pp. 3178–3186.
- [4]. Soteris A. Kalogirou "Solar Energy Engineering: Processes and Systems".
- [5]. Y. Tian, C.Y. Zhao, "A Review of Solar Collectors and Thermal Energy Storage in Solar Thermal Applications".
- [6]. A. Chaurey, TC Kandpal, "Assessment and evaluation of SPV based decentralized rural electrification: an overview" *Renewable and Sustainable Energy Reviews*, Volume 14, 2010, pp. 2266–2278.
- [7]. TV Ramachandra, "Solar energy potential assessment using GIS" *Energy Educational Science Technology*, Volume 18, 2007, pp. 101–114.
- [8]. Projects, Karnataka Power Corporation Limited, Government of Karnataka, Viewed on <http://www.karnatakapower.com/projects.asp>.



Chandani Sharma is a PhD Research Scholar at Graphic Era University, Dehradun. She received M.Tech in Communication Engg. with specialization in Image Processing from Shobhit University, Meerut. She has 8 years of academic experience. Her interest areas include Photovoltaic Systems, Soft Computing, Fuzzy Logic Control Systems and Image Processing. She published over 14 papers. She has been a meritorious student throughout with an active involvement in many projects and workshops/conference conduction.



Dr. Anamika Jain is Professor in Electronics and Communication Engineering Department at Graphic Era University, Dehradun. She received PhD Degree from IIT-Roorkee with specialization in Soft Computing. Her interest areas include Artificial Intelligence, Fuzzy Control Systems and Process Control. She has a vast academic experience of 18 years. She has to her credit more than twenty papers. She is currently supervising three PhD students and more than ten M.Tech and B.Tech students. She has versatile knowledge and a contributor to journal reviews.